



REV.	ECN NO.	REVISED	DATE

NOTE:

1.MATERIAL:

- a.HOUSING:PPA
- b.CONTACT:PHOSPHOR BRONZE  
(SURFACE PLATING: Au1u")

SEE ORDERING INFORMATION

2.ELECTRIC:

- a.CONTACT RESISTANCE: 30 MILLIOHMS MAX
- b.INSULATION RESISTANCE: 1000 MEGA OHMS MIN
- c.DIELECTNIC VOLTAGE: 500V AC ONE SEC LEVEL
- d.OPERATING TEMPERATURE: -25° C~ +85° C

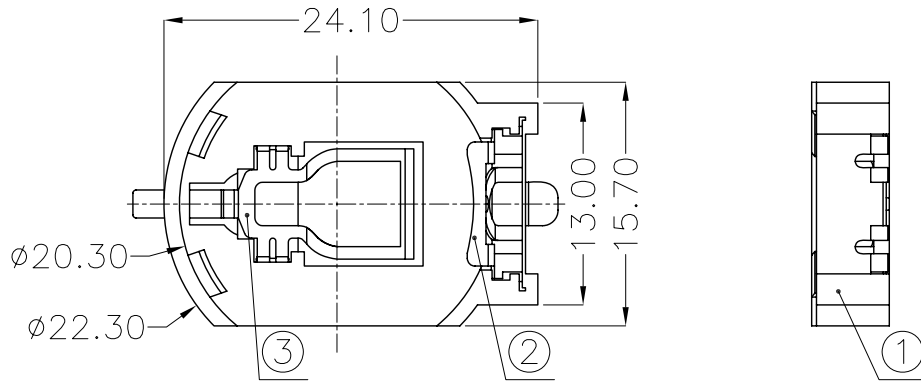

ORDERING INFORMATION

**BS-08-B\*\*\*004**

电池座系列

BS-08系列

SMT 180° TYPE

PLATING:  
A-Au1U"  
J-Ni100U"~120U"  
K-Sn100U"~120U"

MATERIAL:  
1A-PBT BLACK  
1B-PA66 BLACK  
2A-PPA BROWN  
2B-PPA BLACK  
3A-PPS BROWN  
3B-PPS BLACK  
4A-LCP WHITE  
4B-LCP BLACK



PCB Layout Diagram  
Top View

3	TERMINAL(-)	1	PHOSPHOR BRONZE, T=0.20mm	Gold Plating and Ni Under-Plating
2	TERMINAL(+)	1	PHOSPHOR BRONZE, T=0.20mm	Gold Plating and Ni Under-Plating
1	HOUSING	1	PPA	BLACK
NO.	PART NAME	Q'TY	MATERIAL	PLATING & COLOR

UNLESS OTHERWISE SPECIFIED TOLERANCES							
DECIMALS: X :±0.30 X.X :±0.25 X.XX :±0.20 X.XXX :±0.10	ANGLES: X :±1° X.X :±0.5°	DSND	YangFeng	DATE	2017-06-29	TITLE:	
		CHKD	ZhouRuicai	DATE	2017-06-29	BS-2032-8C 5MM SMT	
		APVD	XueShunyong	DATE	2017-06-29	PART NO.:	
		WEIGHT: 0.78g		SCALE: 2:1	SIZE: A4	VIEW:	BS-08-B2BA004
		SHEET 1 OF 1	UNIT: mm	REV.: A/0	OBJECT: MY	DRAW NO.:MY-CP-0062	