

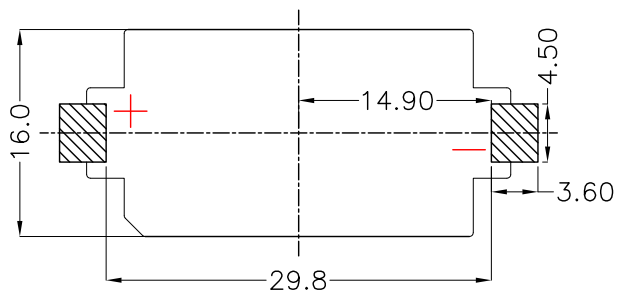

REV.	ECN NO.	REVISED	DATE

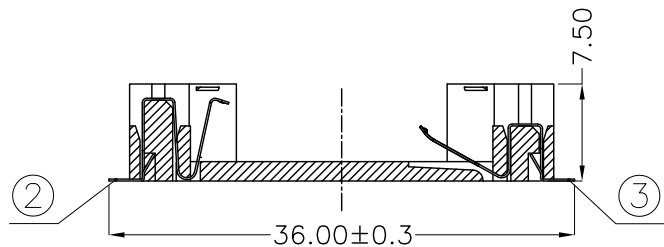
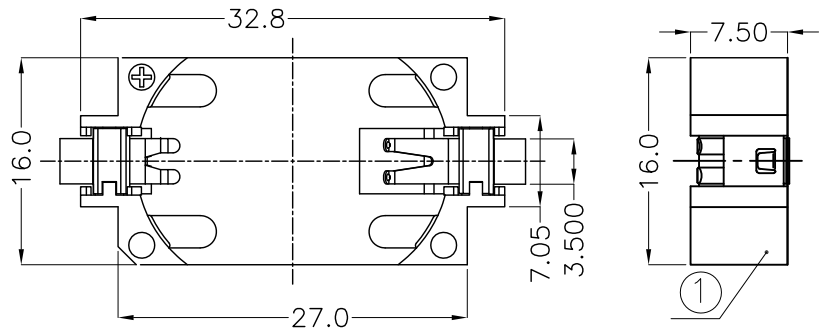

PCB Layout Diagram
Top View

1.MATERIAL:

- a.HOUSING:LCP UL94V-0
- b.CONTACT:PHOSPHOR BRONZE
(SURFACE PLATING: Au1u")

SEE ORDERING INFORMATION

2.ELECTRIC:

- a.CONTACT RESISTANCE: 30 MILLIOHMS MAX
- b.INSULATION RESISTANCE: 1000 MEGA OHMS MIN
- c.DIELECTNIC VOLTAGE: 500V AC ONE SEC LEVEL
- d.OPERATING TEMPERATURE: -25°C~ +85°C

ORDERING INFORMATION

BS-24-B***006

电池座系列

BS-24系列

SMT 180° TYPE

PLATING:
A-Au1U"
J-Ni100U"~120U"
K-Sn100U"~120U"

MATERIAL:
1A-PBT BLACK
1B-PA66 BLACK
2A-PPA BROWN
2B-PPA BLACK
3A-PPS BROWN
3B-PPS BLACK
4A-LCP WHITE
4B-LCP BLACK
5A-PA6T WHITE
5B-PA6T BLACK



NO.	PART NAME	Q'TY	MATERIAL	PLATING & COLOR
3	TERMINAL(-)	1	PHOSPHOR BRONZE, T=0.15mm	Gold Plating and Ni Under-Plating
2	TERMINAL(+)	1	PHOSPHOR BRONZE, T=0.15mm	Gold Plating and Ni Under-Plating
1	HOUSING	1	LCP	WHITE

UNLESS OTHERWISE SPECIFIED TOLERANCES							
DECIMALS: X :±0.30 X.X :±0.25 X.XX :±0.20 X.XXX :±0.10	ANGLES: X :±1° X.X :±0.5°	DSND	YangFeng	DATE	2017-07-11	TITLE: BS-2450-2 Au SMT	
		CHKD	ZhouRuicai	DATE	2017-07-11	PART NO.:	
		APVD	XueShunyong	DATE	2017-07-11	BS-24-B4AA006	
WEIGHT: 1.7g		SCALE: 3:1	SIZE: A4	VIEW:			
SHEET 1 OF 1		UNIT: mm	REV.: A/0	OBJECT: MY	DRAW NO.:WD-CP-0021		