

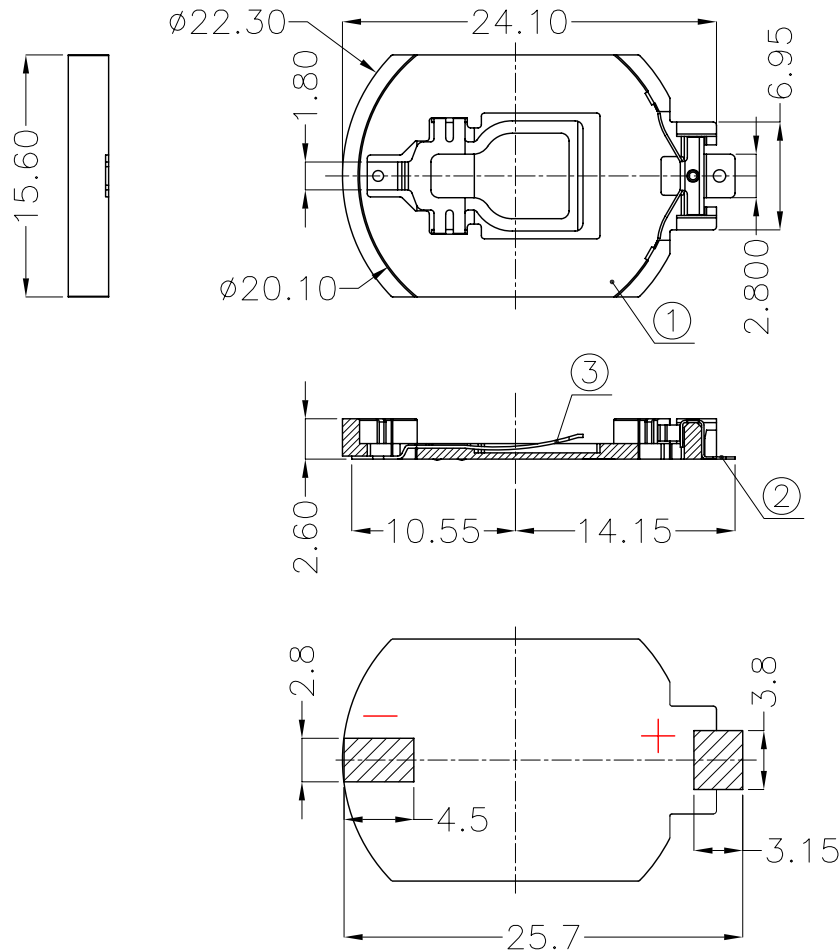

REV.	ECN NO.	REVISED	DATE



PCB Layout Diagram
Top View

NOTE:

- 1.MATERIAL:
 - a.HOUSING:PPA
 - b.CONTACT:PHOSPHOR BRONZE
(SURFACE PLATING: Au1u")
- 2.ELECTRIC:
 - a.CONTACT RESISTANCE: 30 MILLIOHMS MAX
 - b.INSULATION RESISTANCE: 1000 MEGA OHMS MIN
 - c.DIELECTNIC VOLTAGE: 500V AC ONE SEC LEVEL
 - d.OPERATING TEMPERATURE: -25°C~ +85°C

SEE ORDERING INFORMATION

ORDERING INFORMATION
BS-2016-B*001**

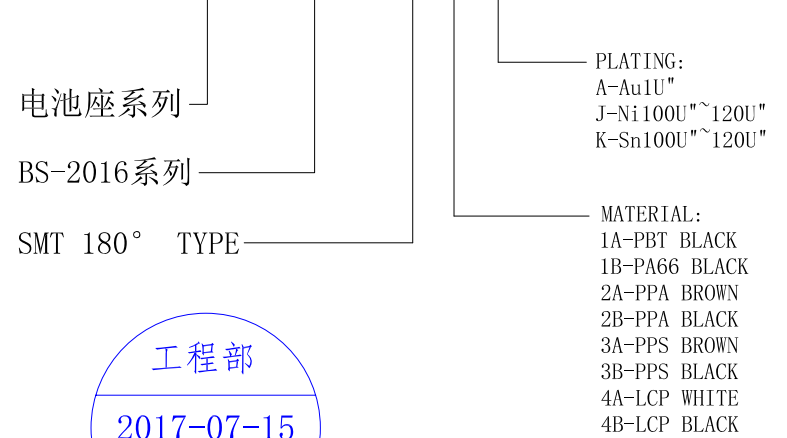

3	TERMINAL(-)	1	PHOSPHOR BRONZE, T=0.20mm	Gold Plating and Ni Under-Plating
2	TERMINAL(+)	1	PHOSPHOR BRONZE, T=0.15mm	Gold Plating and Ni Under-Plating
1	HOUSING	1	PPA	BROWN
NO.	PART NAME	Q'TY	MATERIAL	PLATING & COLOR

UNLESS OTHERWISE SPECIFIED TOLERANCES							
DECIMALS: X :±0.30 X.X :±0.25 X.XX :±0.20 X.XXX :±0.10	ANGLES: X :±1° X.X :±0.5°	DSND	YangFeng	DATE	2017-07-15	TITLE:	
		CHKD	ZhouRuicai	DATE	2017-07-15	BS-2016-8-1 PPA SMT	
		APVD	XueShunyong	DATE	2017-07-15	PART NO.:	
		WEIGHT:	0.66g	SCALE:	2:1	SIZE:	A4
		SHEET	1 OF 1	VIEW:	④ ⊞	REV.:	A/0
		UNIT:	mm	OBJECT:	MY	DRAW NO.:MY-CP-0029	